

USER MANUAL

Sonic Anemometer

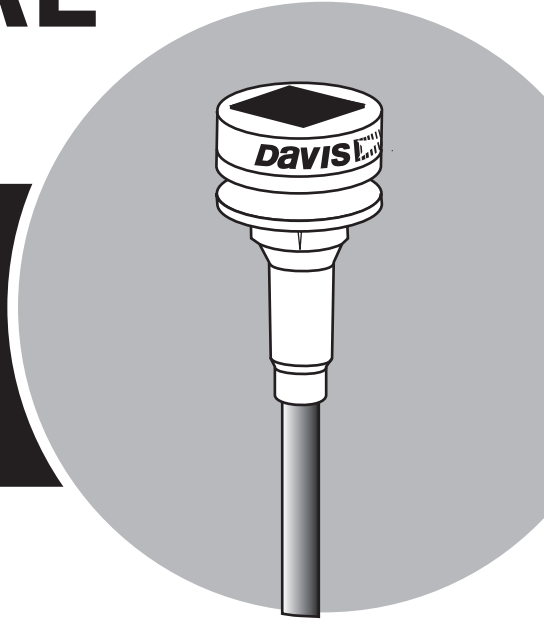

Product number 6415

For Vantage Pro2™, EnviroMonitor®, and Sensor Transmitter

DAVIS ®

Davis Instruments, 3465 Diablo Avenue, Hayward, CA 94545-2778 U.S.A. • 510-732-9229 • www.davisinstruments.com

The Sonic Anemometer is designed to measure wind-related conditions without moving parts. Pairs of electro-acoustic transducers in the anemometer send sonic pulses back and forth, and measure the time it takes for the pulse to travel from one to the other. This time is affected by the movement of the air, which allows the anemometer to calculate wind speed and direction, calibrated by temperature measurements.

The sonic anemometer has its own solar panel which charges its internal battery.

It can be used with an EnviroMonitor Node to add wind data to an EnviroMonitor system, as well as a replacement anemometer to your Davis weather station. Installed in a Sensor Transmitter, it can be used to include additional wind stations in your existing system when reporting to a WeatherLink Live.

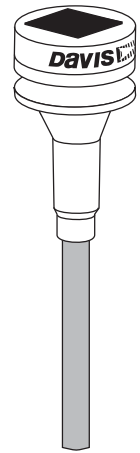

Tools and Materials Needed

You will need the following tools and materials to install your anemometer:

- Cable clips or weather-resistant cable ties

Note: Make sure the clips or ties you use to secure the anemometer cable have screw holes or other means for mounting the cable. Do not use metal staples to secure the cables.

- Small screwdriver
- Adjustable wrench
- Compass
- Screws if mounting on a flat surface

Components

The sonic anemometer includes the components and hardware shown below. Be sure you have all components shown before continuing.

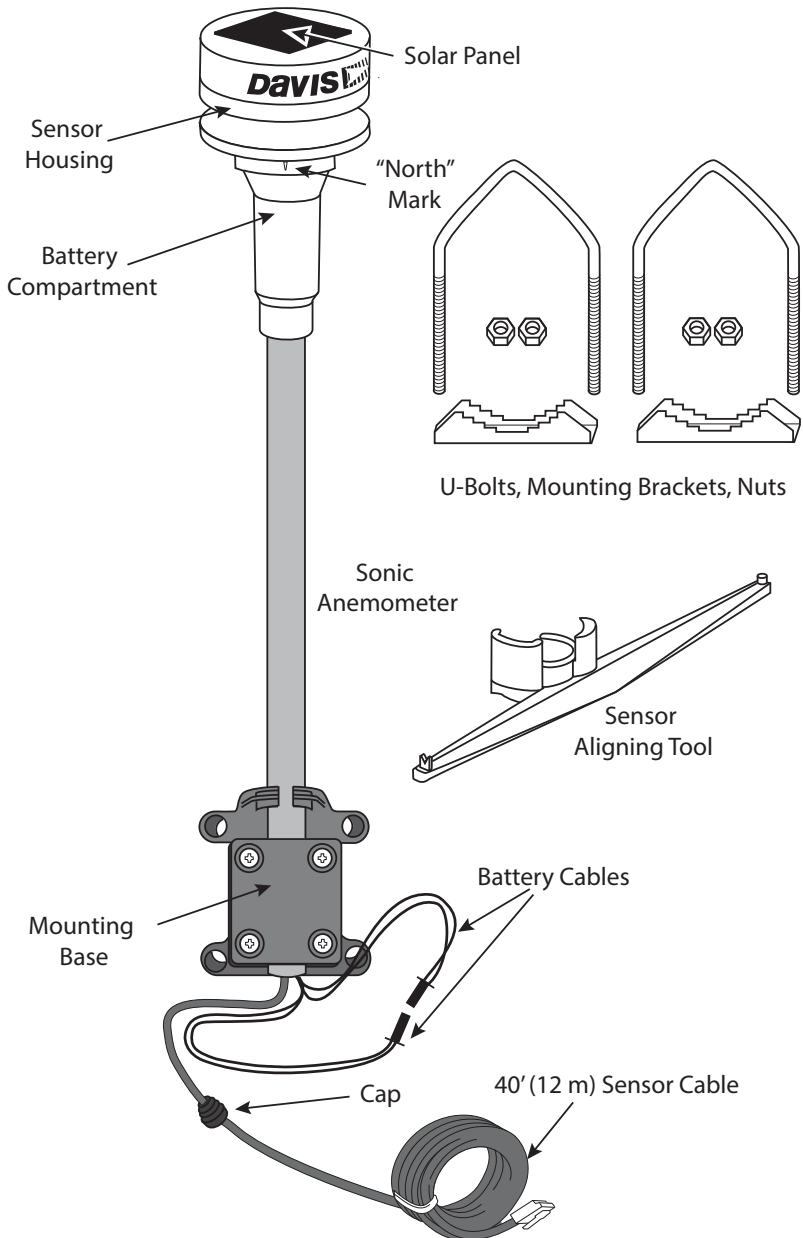

Choose the Mounting Location

Choose a location that is free of turbulence and magnetic fields resulting from electricity, engines, radio transmitters, radars, etc.

Tip: Mount the anemometer where it will receive direct sunlight for several hours each day.

Anemometer Siting Guidelines

- For best results, place the anemometer at least 7' (2.1 m) above surrounding obstructions such as trees or buildings that obstruct wind flow.
- If mounting on a roof, mount the anemometer at least 7' (2.1 m) above the roof apex (when using a Mounting Tripod, install the anemometer at the very top of the pole).
- If mounting the sensor suite and the anemometer together, such as on a pole or a wooden post, mount the anemometer so it is at least 12" (0.3 m) above the top of the rain collector cone for best results.
- The standard for meteorological and aviation applications is to place the anemometer 33' (10 m) above the ground. Seek professional help for this type of installation.
- The standard for *agricultural applications* is to place the anemometer 6' (2 m) above the ground. This is important for evapotranspiration (ET) calculations.

Note: Note: For more detailed siting suggestions, see Application Note #30: Reporting Quality Observations to NOAA on the Davis Support web site (<http://www.davisnet.com/support/weather>).

Connect the Battery

The anemometer includes a factory-installed battery which has been disconnected for shipping. This battery is charged by the solar panel, so you should not connect it until you are ready to install the sensor. Once it is connected, it will lose charge in about 10 days without sunlight. The sensor may need some time in the sun or under a lamp to charge.

1. Connect the two battery cables. (See illustration on page 2.)
2. Push the connected cables into the tube.
3. Push the cap into the end of the tube to seal it.
4. Mount the anemometer in sunlight within 10 days of connecting the battery.

Note: The anemometer requires sunlight on the solar panel before it will turn on, even when the battery is fully charged.

Mount the Sonic Anemometer

Once you have determined the best location, mount your sensor. The Sonic Anemometer comes with a mounting bracket that allows you to mount it either on a pole or on a vertical surface, such as a post or wall.

On a pole, tripod or mast:

Use the included U-bolts and mounting brackets to mount the sensor on a pole with a diameter of 1.4 to 1.9 inches (35 mm - 48 mm).

1. Place the U-bolt around the pole and slide the brackets over the threaded ends with the flat part of the bracket facing outward.
2. Slide the U-bolt ends through the anemometer's square base and loosely install the hex nuts and bolts with a 10 mm wrench.
3. When the anemometer is in the desired place on the pole, tighten the nuts.

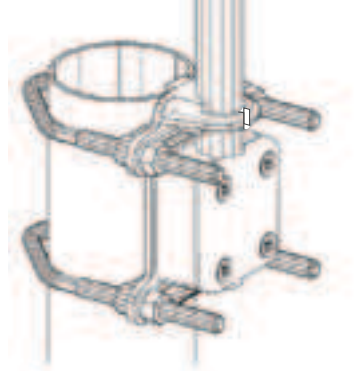

On a vertical surface:

Use M6 or 1/4" lag screws (not included) to mount the sensor to a vertical wooden surface such as a post or wall.

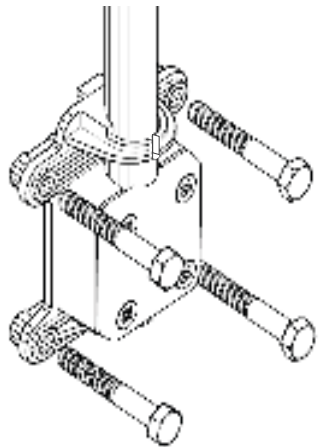

Align the Sensor for Correct Wind Direction

The sensor must be properly aligned for correct wind direction.

Find the small raised “North” mark on the on the sensor housing.

1. Loosen the U-bolts slightly so the tube can be turned.
2. Using a compass, align this mark to True North by turning the tube.
3. Tighten the U-bolts.

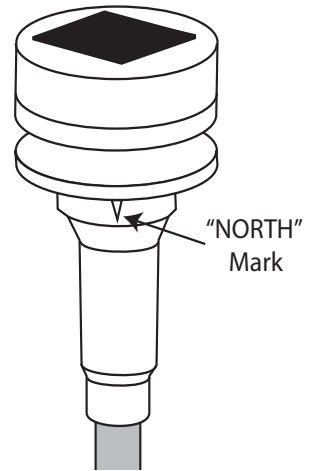

Note: For more precise directional installation, you may use the included aligning tool.

Clip the provided alignment tool on the anemometer tube and slide it until it snaps gently into the dedicated slots on the bottom of the battery compartment.

When correctly in place, the pointed end of the tool will point in the same direction the North mark faces.

Sight through the split end of the tool to align the sensor to True North.

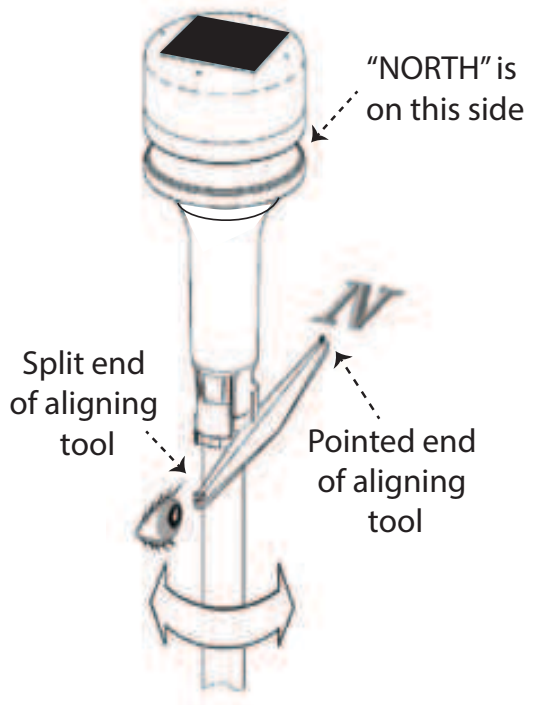

Connect to the Vantage Pro2 Sensor Suite

1. Open the transmitter shelter and disconnect the solar cable so that you can remove the cover.

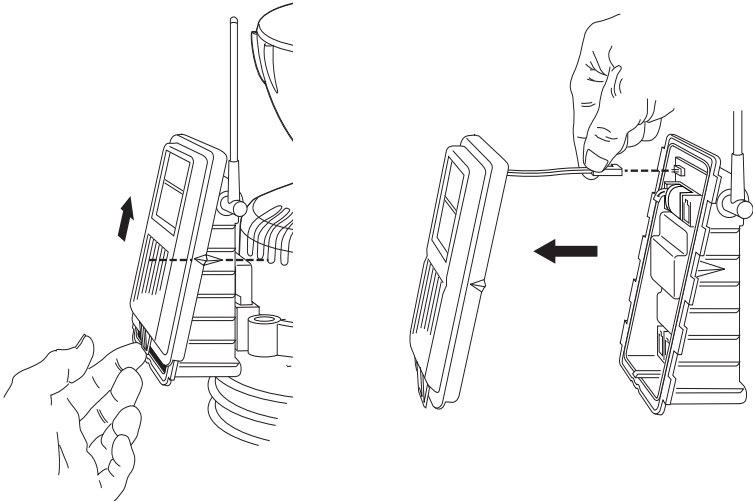

2. Pull the foam insert out of the cable access port and set the foam aside.
3. Insert the Sonic Anemometer cable end into the cable access port from beneath the box.
4. Firmly insert the RJ connector into the socket labeled WIND.
5. Firmly insert the foam in between the cables and at the top of the cable access port, taking care to ensure that the foam seals the access port entirely, leaving no holes or gaps large enough for weather or insects. You may have to stack the cables to allow the foam to fit.

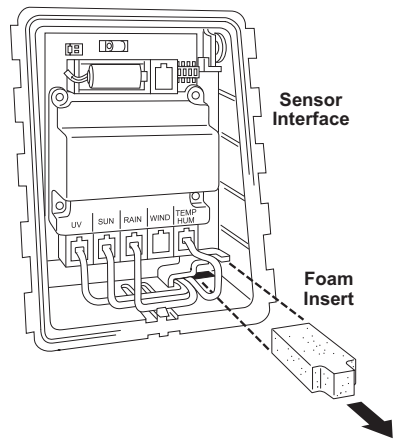

Secure the Cable

To prevent fraying or cutting the anemometer cable where it is exposed to weather, secure it so it doesn't whip about in the wind. Use cable clips or weather resistant cable ties to secure the cable. Place clips or ties approximately every 3 to 5 feet (1 to 1.6 m).

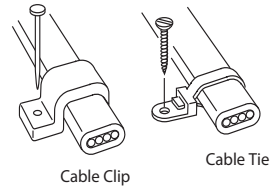

CAUTION: Do not use metal staples to secure cables. Metal staples can cut the cables.

Configure your Console

1. On your Vantage Pro 2 console, enter the Setup Mode by pressing DONE and the - key at the same time.
2. Press DONE repeatedly to scroll through the screens until you come to the Wind Cup Size screen.
3. Press the + and - keys to toggle the sizes until OTHER appears.
4. Press and hold the DONE key to exit Setup Mode and return to the Current Weather Screen.

Start receiving data

Your new Sonic Anemometer will begin sending data after about a minute of initialization and solar exposure before the first packet is sent.

Maintenance

Your Sonic Anemometer itself does not require any regular maintenance other than occasional surface cleaning, including the solar panel, with a clean, soft cloth and clear water. Make sure that airflow is not impeded by dust, spider webs, icicles or other debris.

CAUTION: DO NOT use alcohol-based cleaning products.

Battery Safety Notes

This product has been designed to be powered by a Lithium-ion iron phosphate battery (LiFePO₄) battery. Any other power supply can be hazardous and will void the warranty.

Handle the battery with care. There is a risk of fire if the battery is not correctly handled. Do not attempt to open or repair the battery. Do not press on the battery, do not drill into it, do not place it in a short-circuit situation, do not weld the wires directly on the battery, do not put it in fire or water, and do not expose it to temperatures over 60°C (140°F). Use only original LiFePO₄ batteries with original connectors.

Air transport: When the product is transported by air, the battery must be disconnected. Refer to IATA recommendations.

Troubleshooting

While your anemometer is designed to provide years of trouble-free operation, occasionally problems may arise.

If the recommendations below do not solve the problem, please call Davis Technical Support for further instructions.

? *The battery is fully charged but the anemometer will not turn on.*

Place the solar panel in sunlight for a few hours.

? *Wind speed reads 0 all the time or intermittently or wind direction reading is dashed out.*

- Make sure anemometer is plugged into the jack marked WIND on junction box.
- Check to make sure the battery is connected.
- Check for broken wire along length of anemometer cable. Carefully check areas where the cable has been secured.
- The battery may need to be replaced. Contact Davis Technical Support.
- If you still do not get a reading, the problem is with the anemometer. Contact Davis Technical Support for return authorization.

? *Wind speed reading seems too high or too low.*

- Check for any obstructions blocking the wind near the anemometer.

? *Can I calibrate my anemometer?*

No, the sonic anemometer cannot be calibrated. If you verify that the data is not accurate, the most likely cause is location.

Contacting Davis Instruments Technical Support

For questions about installing or operating your Sonic Anemometer, please contact Davis Technical Support. We'll be glad to help.

Online **www.davisinstruments.com**

See the Weather Support section for copies of user manuals, product specifications, application notes, software updates, and more.

E-mail **support@davisinstruments.com**

Telephone (510) 732-7814
Monday - Friday, 7:00 a.m. - 5:30 p.m. Pacific Time.

Specifications

General

Operating Temperature	+5°F to +131°F (-15°C to +55°C)
Attached Cable Length	40' (12 m)
Cable Type	4-conductor, 26 AWG
Connector	Modular connector (RJ-11)
Maximum Cable Length	250' (76 m)

Sensor Output

Wind Direction

Display Resolution	16 points (22.5°) on compass rose, 1° in numeric display
Accuracy	±2 degrees at wind speeds >7 mph (3 m/s); ±4 degrees at wind speeds < 7 mph (3 m/s)

Wind Speed

Resolution and Units	Measured in 1 mph. Other units are converted from mph and rounded to nearest 1 km/h, 0.1 m/s, or 1 knot
Range	0 to 89 mph, 0 to 78 knots, 0 to 40 m/s, 0 to 144 km/h
Accuracy	±2 mph (2 kts, 3 km/h, 1 m/s) or ±4%, whichever is greater

Input/Output Connections

Black	Wind speed contact closure to ground
Red	Ground
Green	Wind direction pot wiper (20KΩ potentiometer)
Yellow	Pot supply voltage
Wind Speed Translation Formula	$V = P(2.25/T)$ (V = speed in mph, P = no. of pulses per sample period, T = sample period in seconds))
Wind Direction Translation	Variable resistance 0 - 20KΩ; 10KΩ = south, 180°

Sonic Anemometer Installation Manual

Product Number: 6415

Document Part Number: 7395.378 Rev E (2/3/22)

© Davis Instruments Corp. 2022. All rights reserved.

Vantage Pro is a registered trademark of Davis Instruments Corporation, Hayward, CA. Information in this document subject to change without notice. Davis Instruments Quality Management System is ISO 9001 certified.



3465 Diablo Avenue, Hayward, CA 94545-2778 U.S.A.
510-732-9229 • Fax: 510-732-9188
info@davisinstruments.com • www.davisinstruments.com